

5 Gadgets

Describing dimensions, actions and processes | Recognizing words with several meanings | Using collocations and context to identify the right meaning

Vocabulary

Nouns to describe dimensions:

- **angle (angles)**

NOUN An **angle** is the difference in direction between two lines or surfaces. Angles are measured in degrees. ■ *The boat is now leaning at a 30 degree angle.*

- **circumference**

UNCOUNTABLE NOUN The **circumference** of a circle, place, or round object is the distance around its edge. ■ *a scientist calculating the Earth's circumference*
■ *The island is 3.5 km in circumference.*

- **diameter (diameters)**

NOUN The **diameter** of a round object is the length of a straight line that can be drawn across it, passing through the middle of it.
■ *[+ of] a tube less than a fifth of the diameter of a human hair* ■ *a length of 22-mm diameter steel pipe*

- **height (heights)**

NOUN The **height** of a person or thing is their size or length from the bottom to the top. ■ *Her weight is about normal for her height.* ■ *I am 5'6" in height.* ■ *[+ of] The tree can grow to a height of 20ft.* ■ *He was a man of medium height.*

- **length (lengths)**

NOUN The **length** of something is the amount that it measures from one end to the other along the longest side. ■ *It is about a metre in length.* ■ *[+ of] the length of the field*
■ *[+ of] The plane had a wing span of 34ft and a length of 22ft.*

- **radius (radii)**

NOUN The **radius** around a particular point is the distance from it in any direction.

■ *[+ around] Nigel has searched for work in a ten-mile radius around his home.*
■ *[+ of] within a fifty-mile radius of the town*
■ *Fragments of twisted metal were scattered across a wide radius.*

- **volume (volumes)**

NOUN The **volume of** something is the amount of it that there is. ■ *[+ of] Senior officials will be discussing how the volume of sales might be reduced.* ■ *[+ of] the sheer volume of traffic and accidents*

- **width (widths)**

NOUN The **width** of something is the distance it measures from one side or edge to the other. ■ *[+ of] Measure the full width of the window.* ■ *The road was reduced to 18ft in width by adding parking bays.* ■ *Saddles are made in a wide range of different widths.*

Actions:

- **adjust (adjusts, adjusting, adjusted)**

VERB When you **adjust to** a new situation, you get used to it by changing your behaviour or your ideas. ■ *[+ to] We are preparing our fighters to adjust themselves to civil society.* ■ *[+ to] I felt I had adjusted to the idea of being a mother very well.*

- **convey (conveys, conveying, conveyed)**

VERB To **convey** information or feelings means to cause them to be known or understood by someone. ■ *Semiological analysis sees a sign as any cultural symbol which conveys a meaning.* ■ *In every one of her pictures she conveys a sense of immediacy.*
■ *He also conveyed his views and the views of the bureaucracy.*

• **launch (launches, launching, launched)**

VERB If a company **launches** a new product, it makes it available to the public. ■ *Crabtree & Evelyn has just launched a new jam, Worcesterberry Preserve.* ■ *Marks & Spencer recently hired model Linda Evangelista to launch its new range.*

• **reinforce (reinforces, reinforcing, reinforced)**

VERB If something **reinforces** a feeling, situation, or process, it makes it stronger or more intense. ■ *A stronger European Parliament would, they fear, only reinforce the power of the larger countries.* ■ *This sense of privilege tends to be reinforced by the outside world.*

• **secure (secures, securing, secured)**

VERB If you **secure** something that you want or need, you obtain it, often after a lot of effort. [FORMAL] ■ *Federal leaders continued their efforts to secure a ceasefire.* ■ *Graham's achievements helped secure him the job.*

• **suspend (suspends, suspending, suspended)**

VERB If you **suspend** something, you delay it or stop it from happening for a while or until a decision is made about it. ■ *The union suspended strike action this week.* ■ [+ until] *A U.N. official said aid programs will be suspended until there's adequate protection for relief convoys.*

Practice exercises

1 Match the words a-h to pictures 1-8.

a angle

c diameter

e length

g volume

b circumference

d height

f radius

h width

1 _____

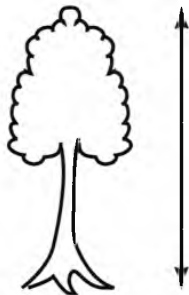

2 _____

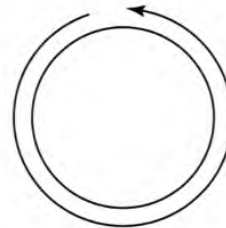

3 _____



4 _____

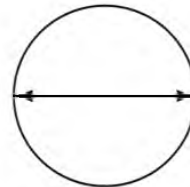

5 _____

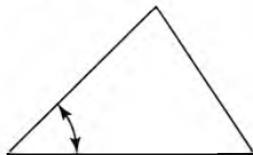

6 _____

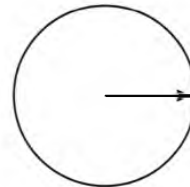

7 _____



8 _____

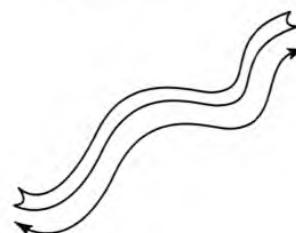



2 Listen to the description of the pinhole camera and complete the diagram by writing the correct dimensions in gaps 1–4.

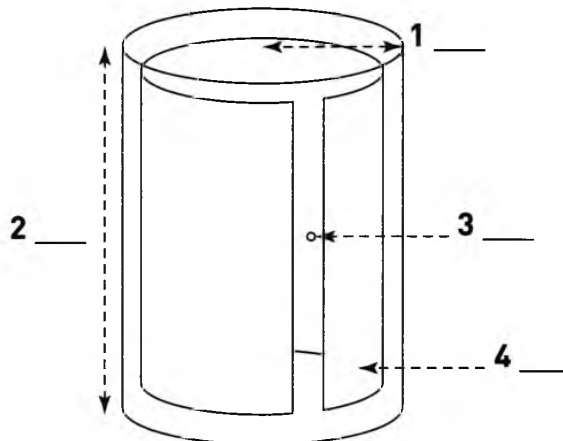

Exam tip: Many words in English have more than one meaning.

You need to pay attention to the context so that you interpret words correctly. Collocations (words that commonly go together) can help you recognize which meaning of a word is intended in that context.

Example: *If you **convey goods** from one place to another you carry or transport them. If you **convey a message** you make it understood.*

Learn to recognize collocations and the multiple meanings of words.

3 Use the words from the box to complete sentence pairs 1–5.

adjust	launch	reinforce	secure	suspend
--------	--------	-----------	--------	---------

- 1 a We had to _____ the meeting because the fire alarm went off unexpectedly.
b If you _____ the light directly above the object, you will see it's shape more clearly.
- 2 a When we noticed the bulge in the wall, we had to call in the builders to _____ it.
b He produced some good data to _____ his argument.
- 3 a You'll have to _____ that camera lens to get a clear image.
b It took me several years to _____ to the climate in Nairobi.
- 4 a Few countries have the facilities to _____ a rocket into space.
b The company are hoping to _____ the new phone in time for Christmas.
- 5 a In order to buy a house, you have to _____ a loan.
b if you want the bookcase to stay in place, you should _____ it to the wall.



4

Listen to sentences 1–5, which contain the verbs from exercise 3. Indicate the meaning of the verb in bold by circling a or b.

- 1 In this sentence does **adjust** mean:
 - a change something to make it more effective? Or
 - b get used to something?
- 2 In this sentence does **launch** mean:
 - a send something into the air? Or
 - b make something available to the public?
- 3 In this sentence does **reinforce** mean:
 - a make something stronger? Or
 - b give evidence to support an idea?
- 4 In this sentence does **secure** mean:
 - a obtain? Or
 - b fasten?
- 5 In this sentence does **suspend** mean:
 - a stop or delay an activity? Or
 - b hang something?



Exam practice: Listening – labelling a diagram – classifying

You are going to hear three students talking about a project for a course in product design. They have been instructed to create a device which will convey a ping-pong ball between two tables positioned a metre apart. Listen and match the suggestions with the person who makes them by writing the correct letter A, B or C next to questions 1–6.

Exam tip: Listen for collocations and context to recognize the meaning of key verbs.

A Lisa

B Bill

C Omar

- 1 project the ball into the air _____
- 2 hang a paper bridge between the tables _____
- 3 fasten the strips of paper together with clips _____
- 4 tie the bridge to the table _____
- 5 create a tube from the strips of paper _____
- 6 make the structure stronger _____